

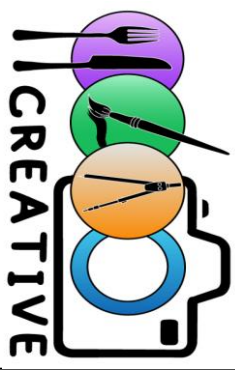

# DIAGNOSTIC ART PROJECT

## YEAR 8



# PORTRAITS, MASKS & PATTERN

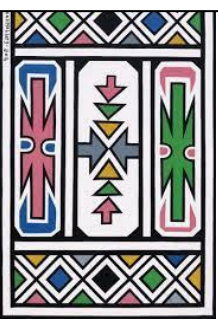
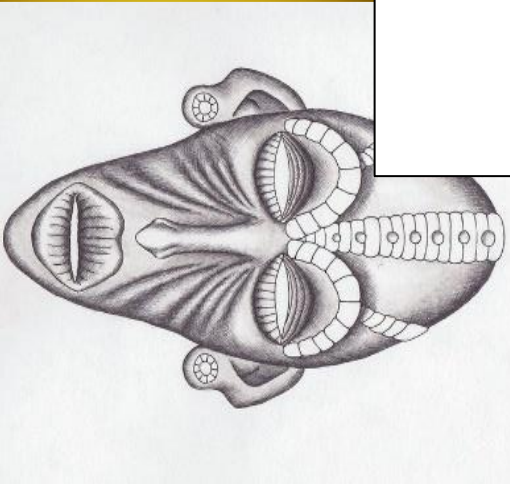

Name: .....

Form: .....

Teacher: .....

Group: .....

# Be PROUD of your work!



Always write the date as Monday 16<sup>th</sup> November 2023



Always write the title and use appropriate Capital Letters.



Always write classwork or home learning at the top of margin.



Always underline with a ruler all dates, titles and headings.



Always write in **black** pen for class work, **green** pen for feedback



Always draw in pencil.



Always use your best handwriting.



Always glue in your worksheets.

Securing Life Chances for ALL

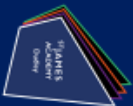

THINK AND SPEAK LIKE A...  
Artist

An open door to mastering vocabulary. Up the stairs to know more and down the stairs to remember more.....

<p><u>Year 7</u></p> <ul style="list-style-type: none"> <li>Tone</li> <li>Texture</li> <li>Value Scale</li> <li>Midtone</li> <li>Colour</li> <li>Tint</li> <li>Primary</li> </ul>	<p><u>Year 8</u></p> <ul style="list-style-type: none"> <li>Proportion</li> <li>Portrait</li> <li>Angles</li> <li>Mark Making</li> <li>Van Gogh</li> <li>Cultural</li> <li>Contemporary</li> <li>Shadow</li> <li>Highlights</li> </ul>	<p><u>Year 9</u></p> <ul style="list-style-type: none"> <li>Pop Art</li> <li>Vivid</li> <li>Outline</li> <li>Popular culture</li> <li>Graphic</li> <li>Advertising</li> <li>Editorial</li> <li>Hyper realism</li> <li>Oromatopoeia</li> <li>Pattern</li> <li>Context</li> </ul>	<p><u>Year 10</u></p> <ul style="list-style-type: none"> <li>Refined</li> <li>Media</li> <li>Iconic</li> <li>Curved</li> <li>Depth</li> <li>Background</li> <li>Foreground</li> <li>Technique</li> <li>Stylised</li> <li>Composition</li> <li>Perspective</li> <li>Symbolism</li> <li>Balance</li> <li>Line quality</li> <li>Realism</li> </ul>	<p><u>Year 11</u></p> <ul style="list-style-type: none"> <li>Pointillism</li> <li>Critical analysis</li> <li>Mixed media</li> <li>Installation</li> <li>Minimalism</li> <li>Surrealism</li> <li>Abstract</li> <li>Emphasis</li> <li>Harmony</li> <li>Final piece</li> <li>Historical research</li> <li>Space</li> <li>Narrative</li> <li>Skill life</li> <li>Collage</li> <li>Experimentation</li> <li>Sculpture</li> <li>Photorealism</li> </ul>
---	--	---	---	---

# METACOGNITION IN MY CLASSROOM

Based on Barak Rosenshine's  
*Principles of Instruction*

How My Teacher Helps Me Learn.

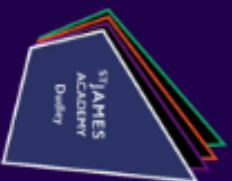

## REVIEWING LEARNING THROUGH DNA

We review our learning daily, this is to help us remember our learning from last week/last month and even last

## QUESTIONING ALL LEARNERS

We are asked a lot of questions to help us think harder. We use metacognitive talk and good oracy to express our thinking and responses.



## PRESENT NEW MATERIALS USING SMALL STEPS

Our teachers break down information into small steps to help us understand.



## MODELLING

We have models and examples which help us understand what a good one looks like.



## SUPPORT

Our teachers provide support in different ways to help us complete our work.



## GUIDED PRACTICE

Our teachers help us become more confident and to make fewer mistakes through guiding our practice.



## AT LEAST 80% SUCCESS RATE

Our teacher encourage us to aim for good success by having a culture of achieving and recognising our success rate.



## INDEPENDENT PRACTICE

We complete work by ourselves when we are ready.



## METACOGNITIVE PRACTICES

- In our lessons, we use:
- Metacognitive talk
  - Assessment wrappers
  - Planning Time
  - Monitoring Time
  - Evaluative Time
  - Feynman Study Model (KSA)

## METACOGNITION

We regularly build our knowledge of metacognition through the tasks we do, our knowledge of self and the strategies that work best for us.

### Mixed media project

- Experimenting with a variety of different media including paint, pencil, ball point pen, collaging
- Outcome to create a mixed media African mask



Summer Term 2



### Contemporary Art

- What is cultural art
- African culture – Ndebele patterns
- Which artists work in this style (Marcus Roman)
- Collaging technique

Summer Term 1

### Gustav Klimt – historical artist

- Investigating Klimt and his style
- Linking geometrical patterns to Klimt style work
- Photography Portrait – in the style of Klimt
- Klimt's colour pallet



Spring Term 2



### Julian Opie – contemporary artist

- Researching artist inspired and contemporary portraits
- Photography self portrait
- Flat colours and what are they
- Julian Opie inspired portrait

Spring Term 1

### Portraiture

- Drawing facial features
- Understanding proportions
- The structure of the human head
- Realistic eyes, nose & mouth
- Observational drawing

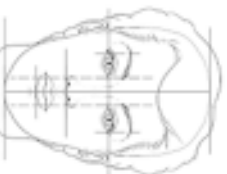

Autumn Term 2



### Historical Research

- Baseline knowledge test
- Artist research – Leonardo Da Vinci and the Mona Lisa
- Value scales
- Ball point pen shading
- The history of portraits from Victorian to current day selfies

Autumn Term 1



# Art Year 8 Glossary – space to add your own words



Essential Language	Definition
Tonal shading	The variation of shading from light to dark
Line	A continuous mark made on a surface by a moving point
Portrait	A picture of painting of a person/animal, a portrait is not created by the sitter
Structure	A 2-dimensional area defined by its outline used to create patterns.
Proportion	The relationship between parts of art such as size or scale
Composition	How lines, shapes and colours are placed in art
Contemporary	Something that is here and now – for an example an artist who is alive and working
Pattern	A repeated decorated design created usually using shapes, lines or colour
Cultural	The ideas, beliefs, customs, thoughts and ways of living of a certain group of people
Abstract	Art that does not look like a simple sketch, often uses shape, colours and lines
Geometric	A simple shape such as square, triangle or circle that have rules based on maths.; often found in patterns.
Art history	Tells us about important events in art history

# YEAR 8 DRAWING NO TALKING. EXAM CONDITIONS

You have two lessons to draw and shade a leaf.

- Fill a piece of A4 paper with your drawing.
- Add detail. For example: Veins & Cells.
- Shading your leaf will help you achieve a higher grade.



**Progress Indicators:**  
**Excellent**

Leaf looks 3D.  
Leaf shaded using Dark, Medium & Light tones.  
Shadows & highlights added.



**Progress Indicators:**  
**Good**

Accurate shape including veins.  
Pencil shading: Dark, Medium & Light tones

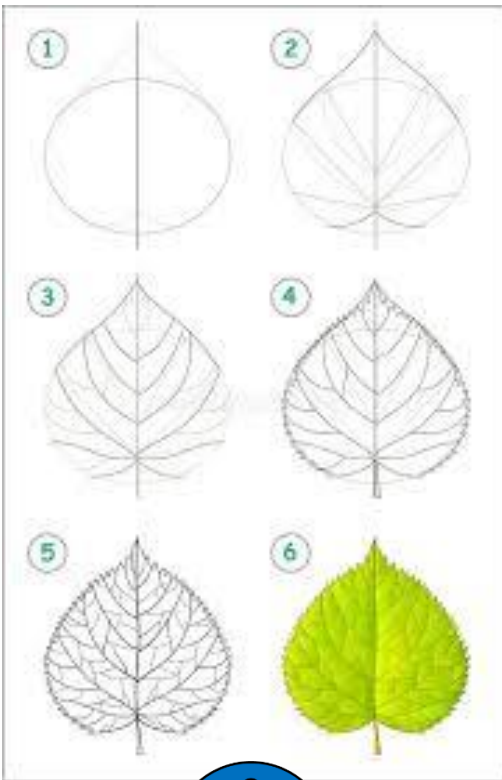
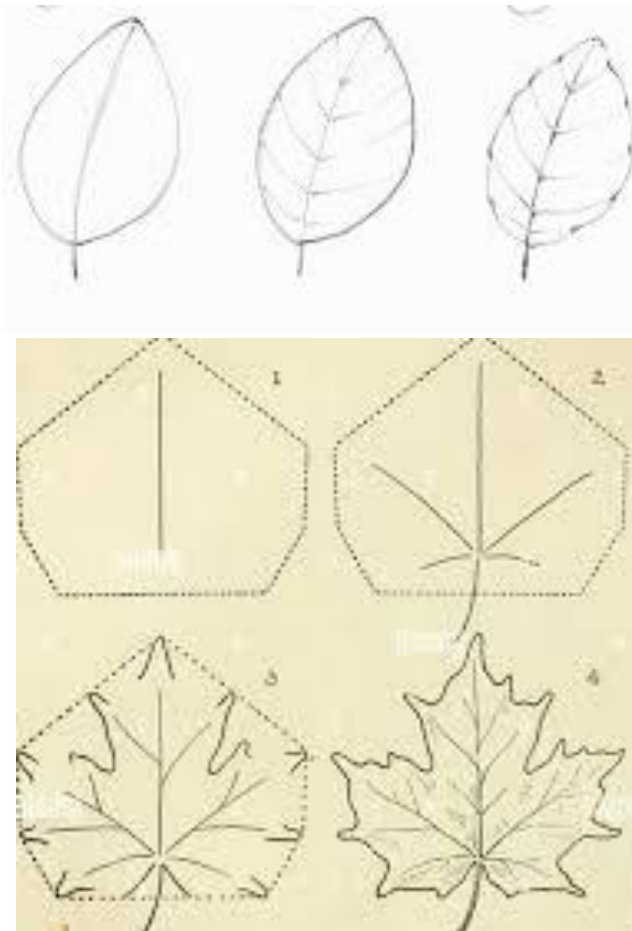

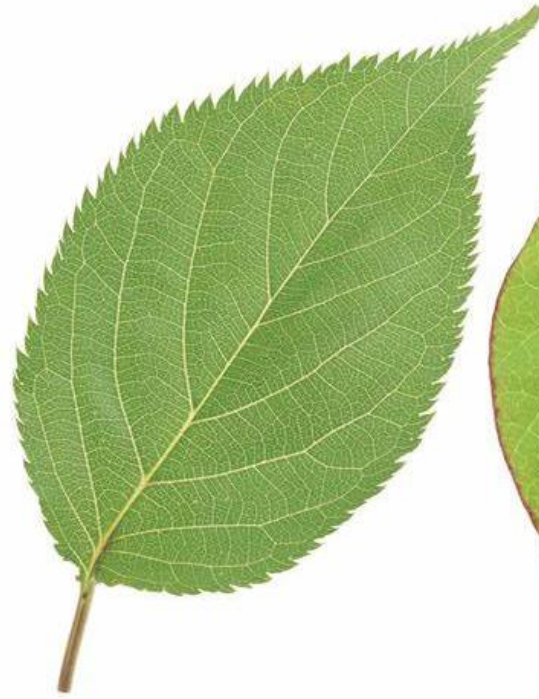

Glue your drawing of a leaf on this page.

**Task 1:**

Shade a VALUE SCALE using ballpoint pen.

Work from DARK – Light.

**Task 2:**

Shade Mona Lisa using ballpoint pen.

Use Light, Medium & Dark shading.

**Task 3:**

Add information about what a PORTRAIT is around  
Mona Lisa.



**KEY WORDS:**  
Value Scale  
Portrait  
Mona Lisa

A **PORTRAIT** is an image of a person or animal.  
It could take the form of a drawing, a painting, a print or a photograph.

A **PORTRAIT** is not created by the sitter but by an artist.

A **SELF PORTRAIT** is a drawing,

painting, print or photograph of an artist, drawn by the artist.

**PORTRAITS** were a way of creating an image of a person before photography was invented in 1839.

A good **PORTRAIT** will do more than show a likeness of a person. It will also

tell you something about their personality, age, interests and status or wealth.

A portrait will show what  
hairstyles and clothing were fashionable.



COPYRIGHT 2008 MARGARET ESAMKI. LICENSED TO ABOUT.COM

Effort:  
WWW:  
EBI:

Use this space to practice your work

# Structure of the human face

Follow the instruction to draw the proportions of the human face

- 1: Draw an egg shape.
- 2: Draw and label the lines.  
Use a ruler to help you.

Don't draw:

- The hair
- The eyes
- The eyebrows
- The nose
- The lips

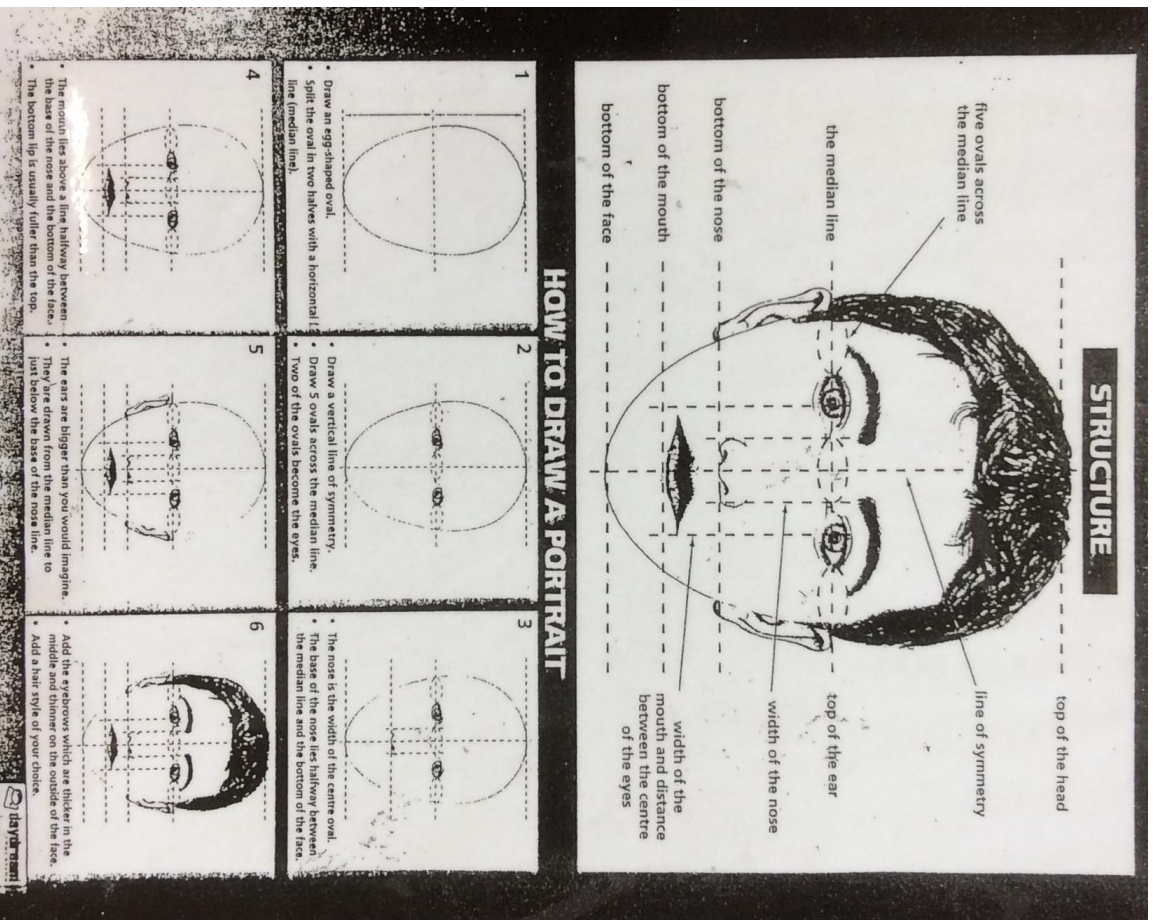

## KEY WORDS:

- Structure
- Proportion
- Construction

# Structure of the human face

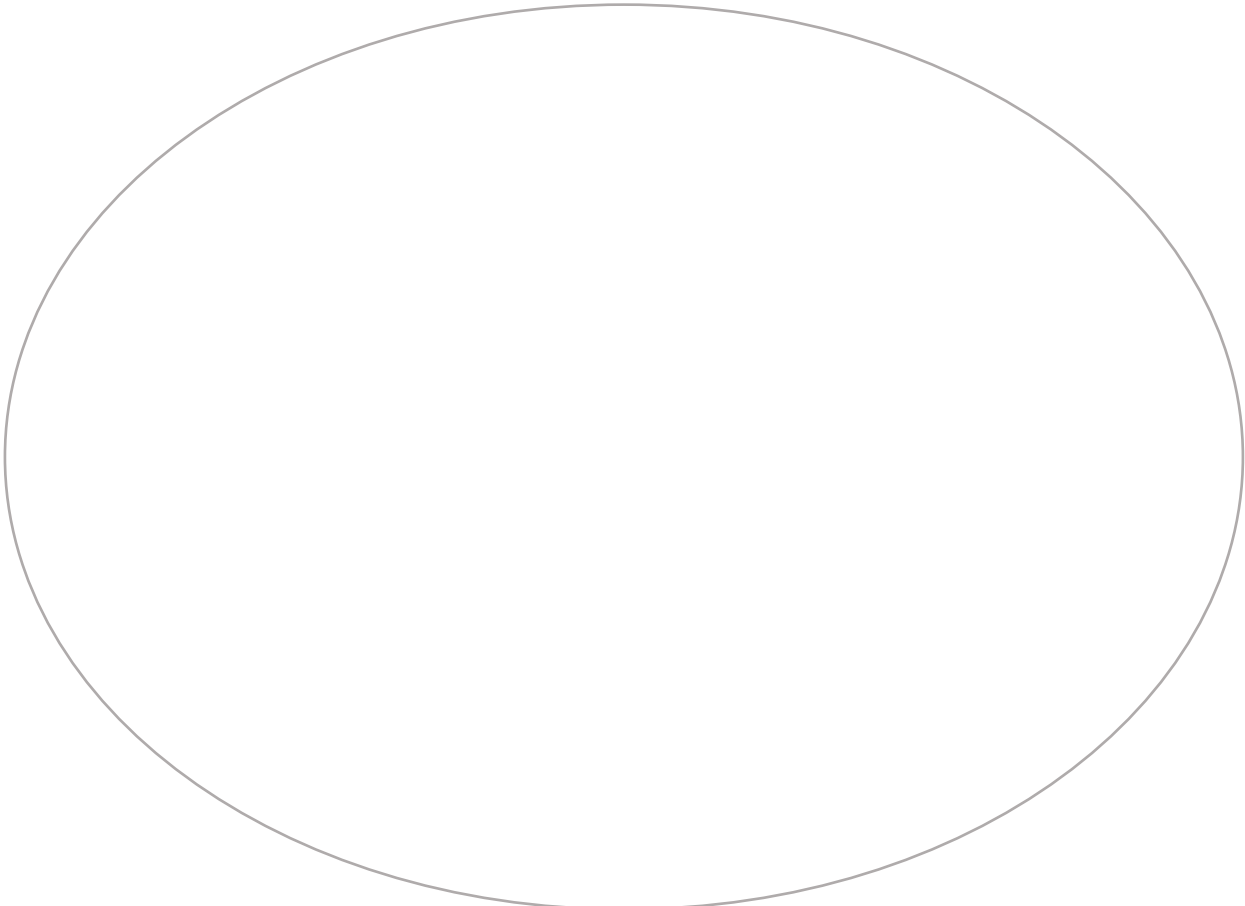

Effort:

WWW/:

EBI:

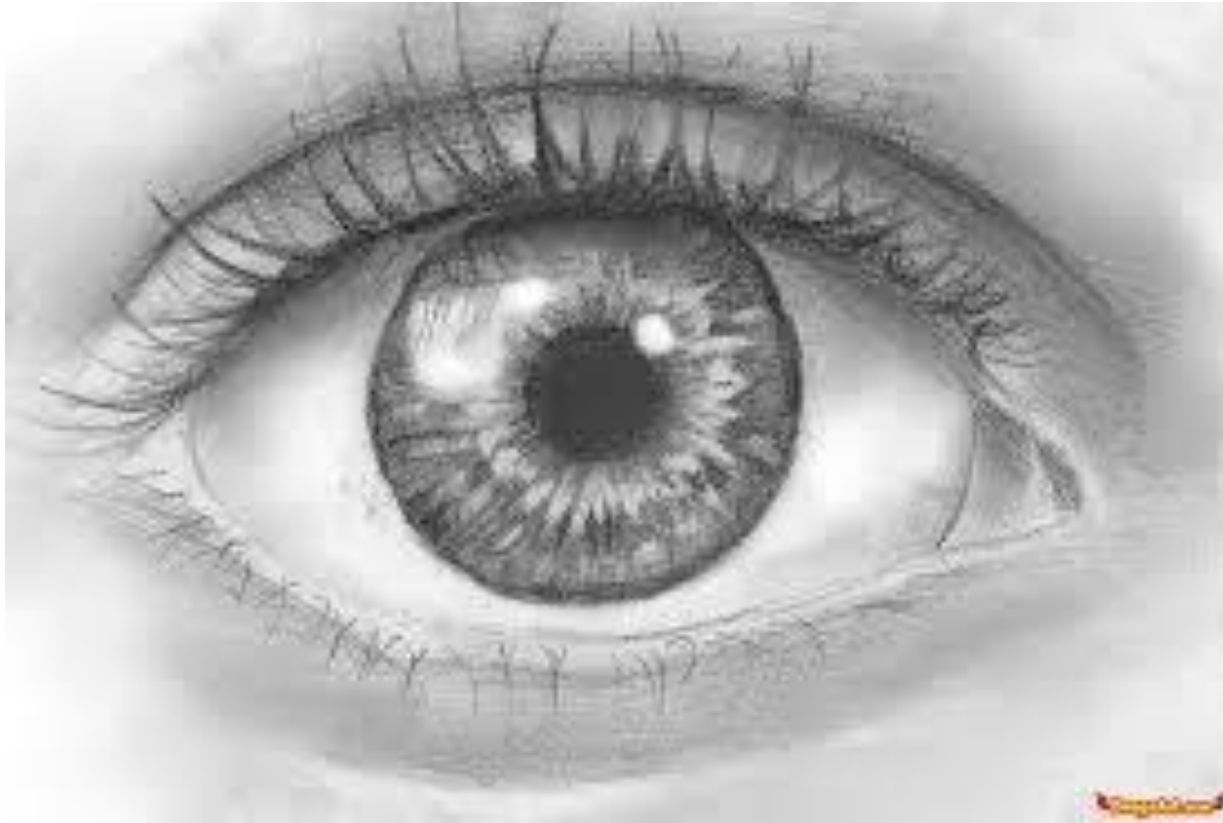

**Value Scale**

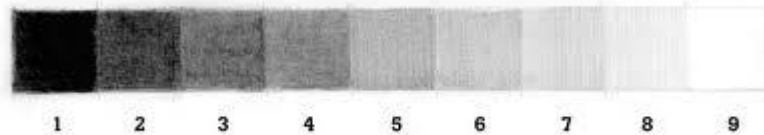

Effort:  
WWW:  
EBI:

## Assessment Feedback

Stick the assessment sheet here.

Use this space to practice your work

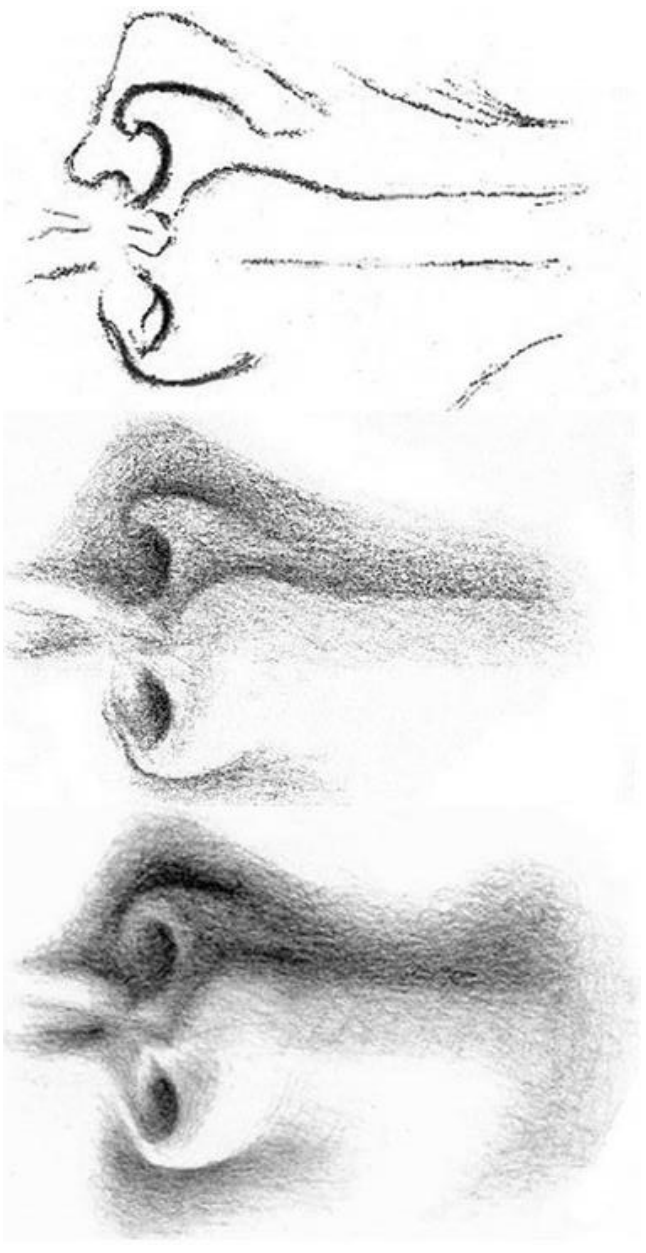

**Value Scale**



Effort:

WWW:

EBI:

Draw 4 different hair styles



Effort:

WWW/:

EBI:





## Assessment Feedback

Stick the assessment sheet here.

# Elements of Art

These are the basic elements that are used by Artists in creating Art; they are what you use to create an aesthetically pleasing work. When we make Art, we need to understand and apply these seven Elements of Art.



## Line

A mark made by a pointed tool such as a brush, pen or stick; a moving point.



## Shape

A flat, enclosed area that has two dimensions, length and width. Artists use both geometric and organic shapes.



## Color

Is one of the most dominant elements. It is created by light. There are three properties of color; Hue (name,) Value (shades and tints,) and Intensity (brightness.)

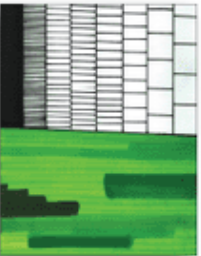

## Value

Degrees of lightness or darkness. The difference between values is called value contrast.



## Form

Objects that are three-dimensional having length, width and height. They can be viewed from many sides. Forms take up space and volume.

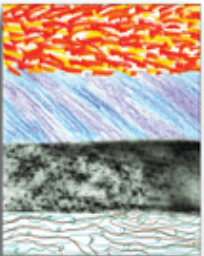

## Texture

Describes the feel of an actual surface. The surface quality of an object; can be real or implied.



## Space

Is used to create the illusion of depth. Space can be two-dimensional, three-dimensional, negative and/or positive.



Julian Opie is a contemporary  
British artist.

**Contemporary:**  
An artist who is alive & creating  
artwork.

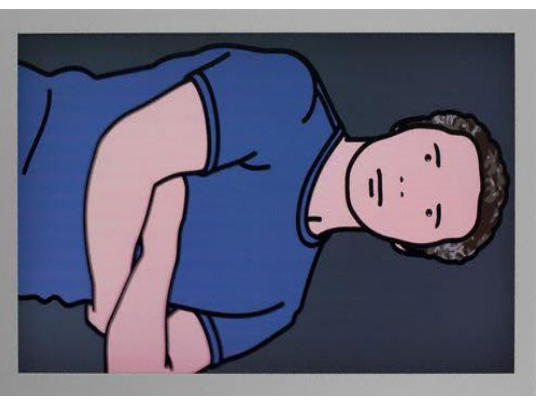

Opie traces the outline of a photograph.  
Eyes and noses are replaced by dots.  
Mouths are replaced by two lines.

**KEY WORDS:**

Contemporary

Trace

Line



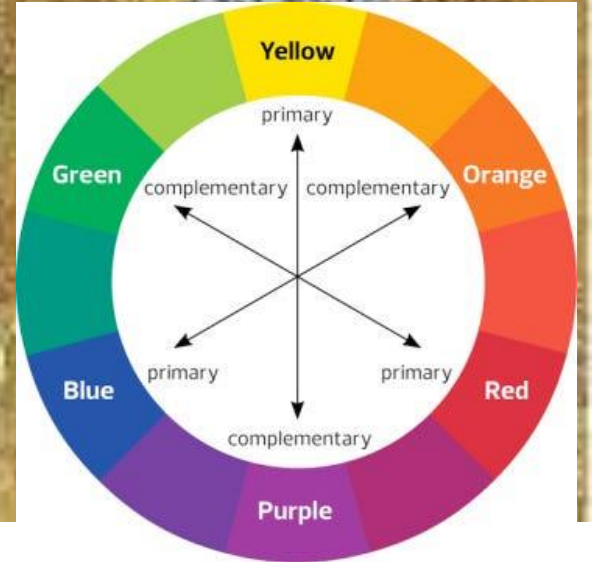
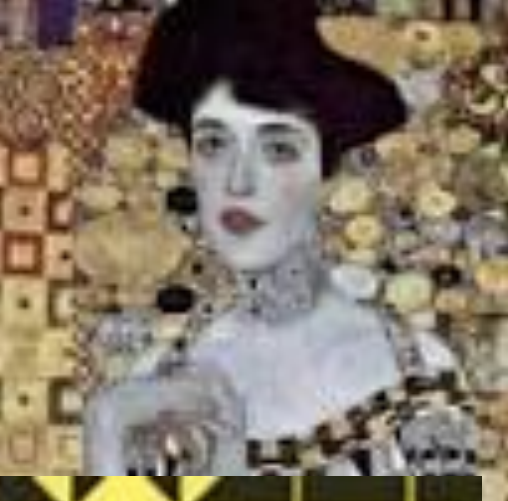

# GUSTAV KLIMT

## 1862-1918

Gustav Klimt lived in Vienna, Austria. Klimt started his career as an apprentice in his father's jewellery business. His work included engraving geometric patterns onto the surface of gold jewellery.

Klimt's first paintings as a professional artist were Landscapes.

Klimt painted portraits of women, surrounded by geometric patterns. Including; Spirals, Triangles, Squares, Circles, Diamonds and eye shapes. The patterns used by Klimt were the same patterns he engraved onto gold as an apprentice jeweller. Klimt added gold leaf to his paintings to make the portraits look like jewellery.

His portraits made Klimt a rich man. Klimt is one of the most copied artists. His work is regularly used by designers and advertisers.





# GUSTAV KLIMT



--	--	--

Effort:  
WWW:  
EBI:

Use this space to practice your work

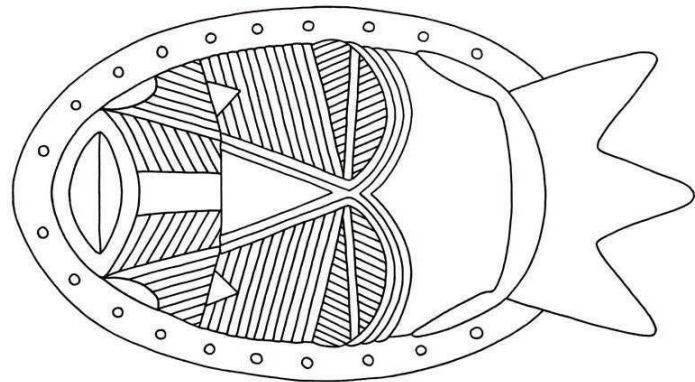
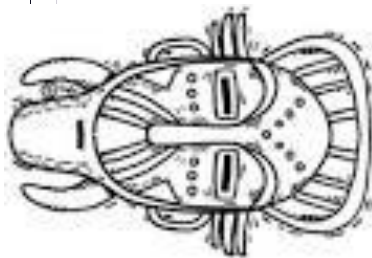
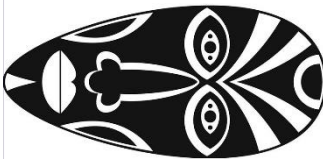
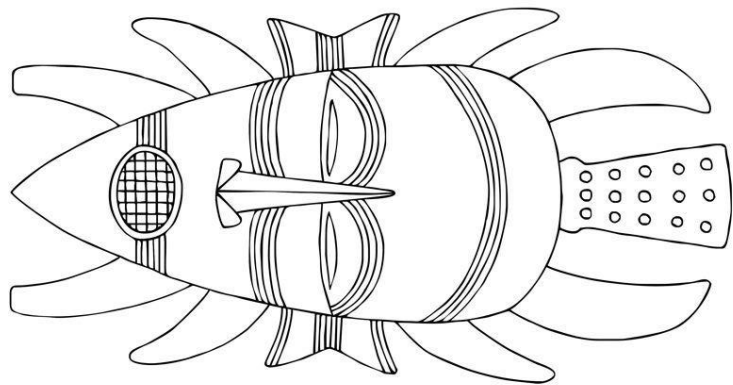
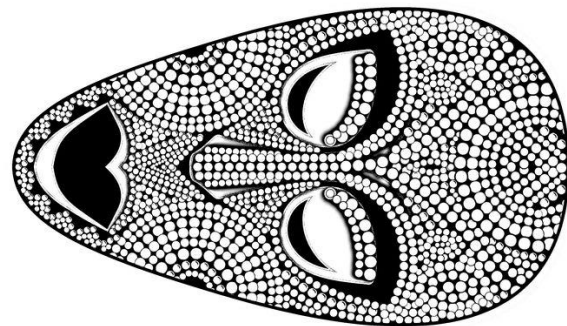
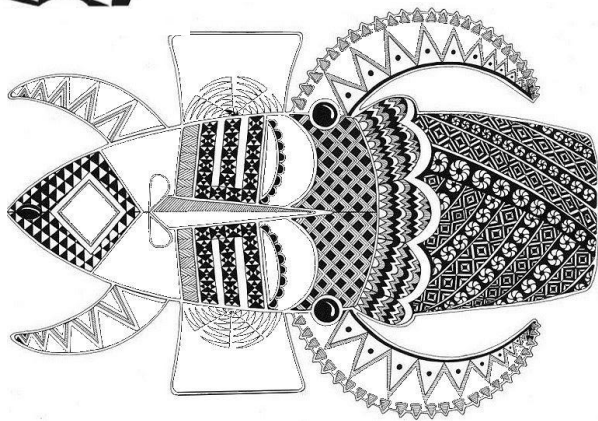
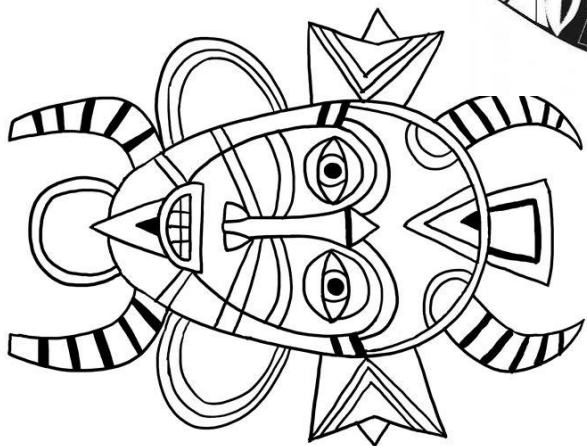
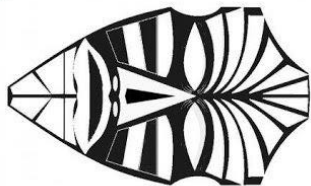
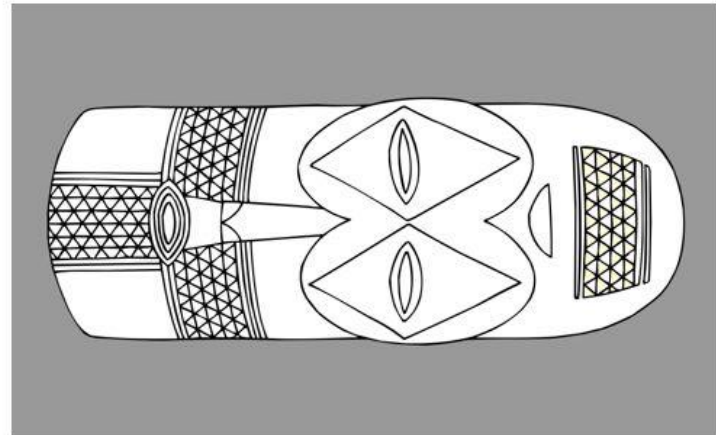
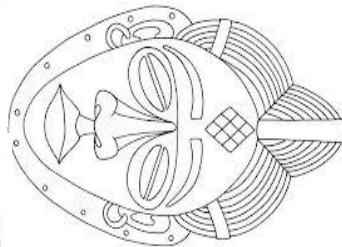
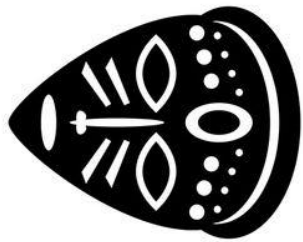
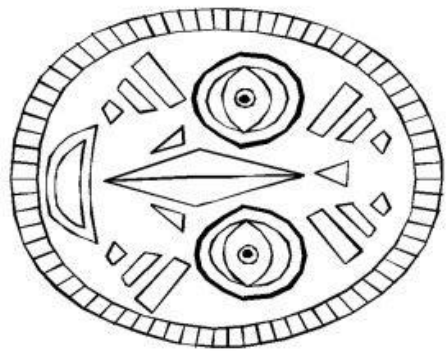

Effort:

WWW:

EBI:



Effort:

WWWV:

EBI:

African  
Masks

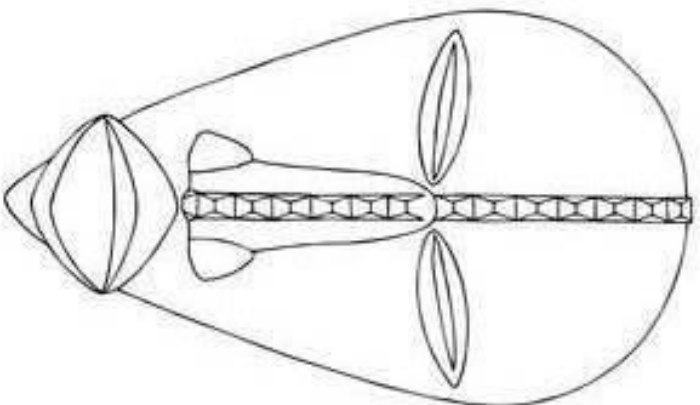
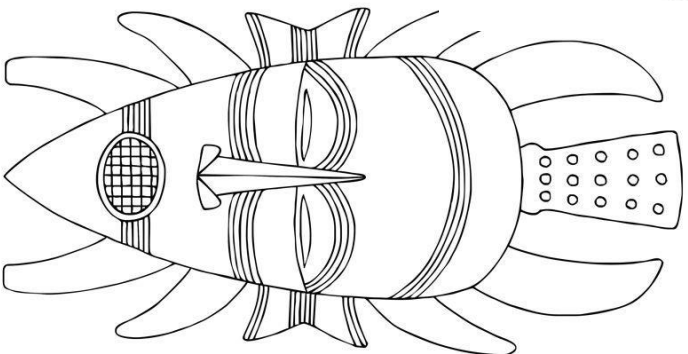
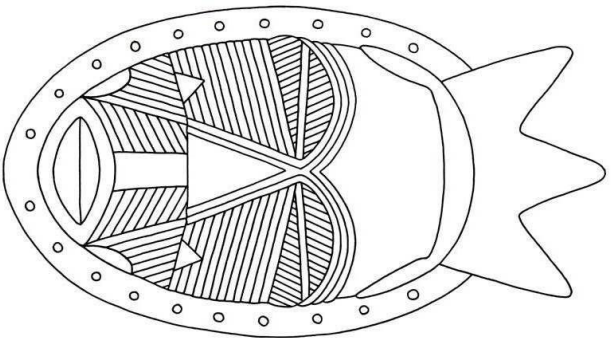

Use these images to help you.

Marcos Roman Masks

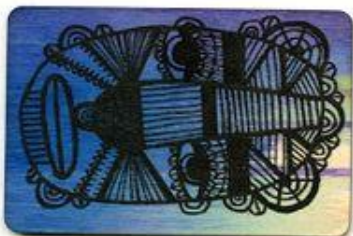

Effort:

WWWV:

EBI:

# AFRICAN NDEBELE PATTERNS



Effort:

WWW:

EBI:



Effort:

WWWV:

EBI:

Use this space to practice your work

Complete a Mixed Media Final Outcome.

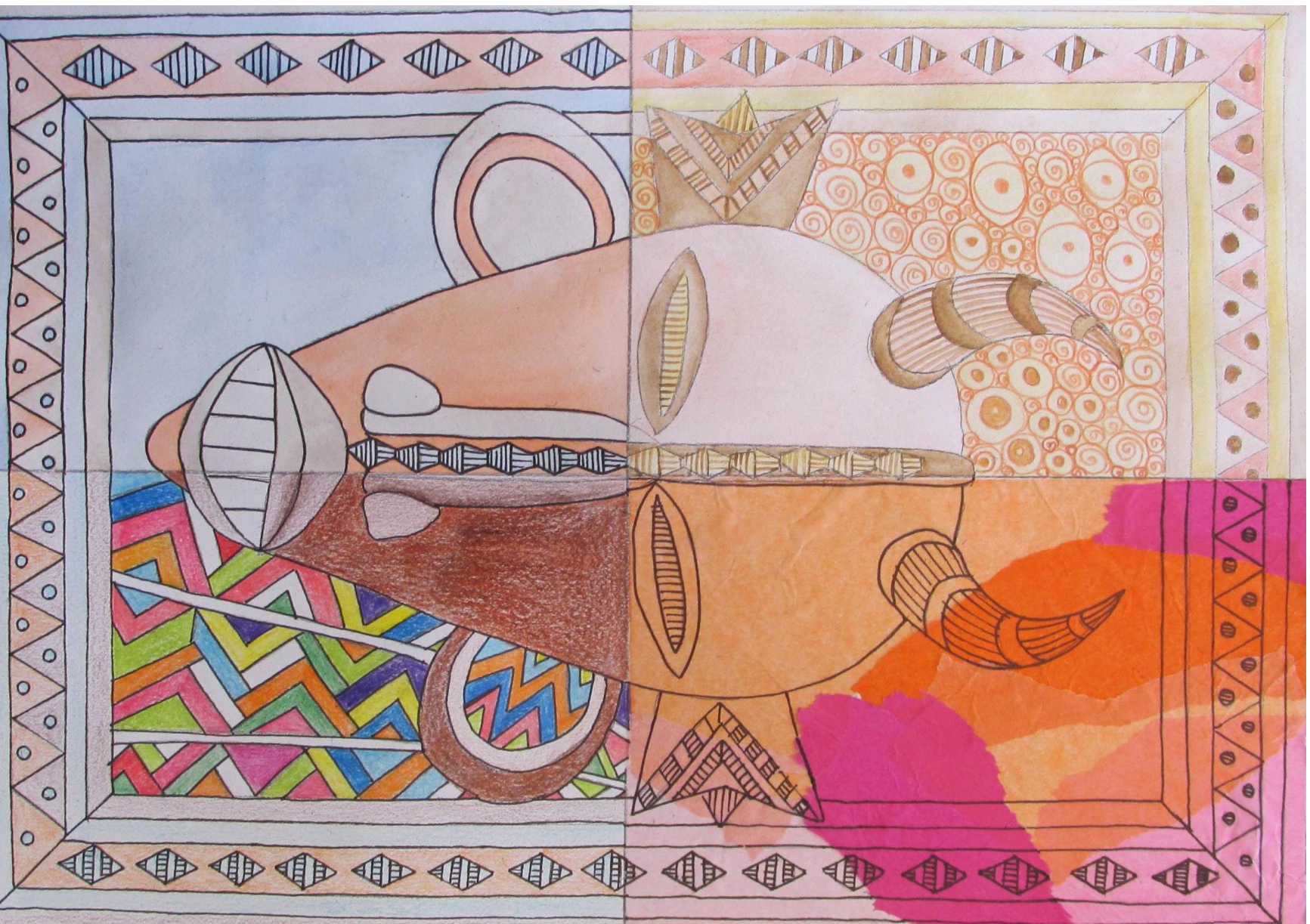



## Assessment Feedback

Stick the assessment sheet here.

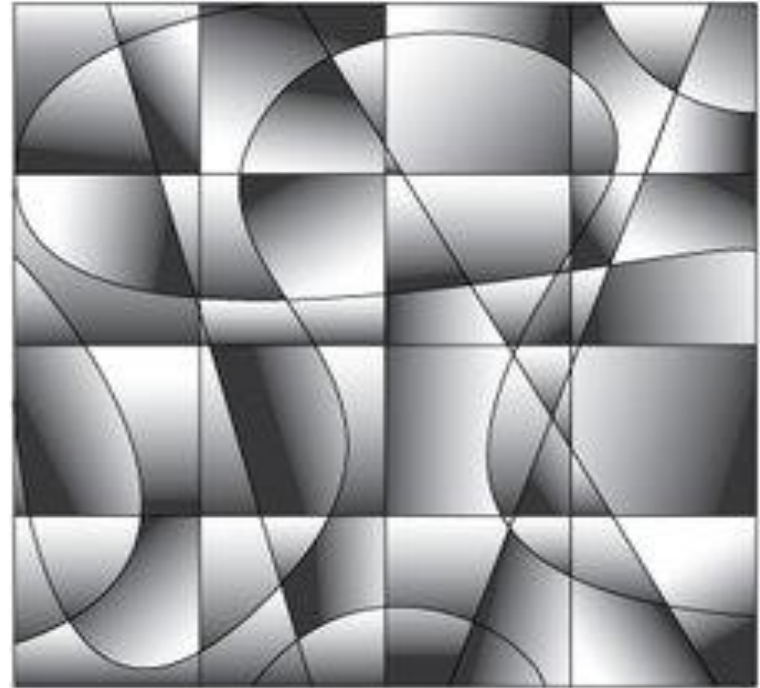
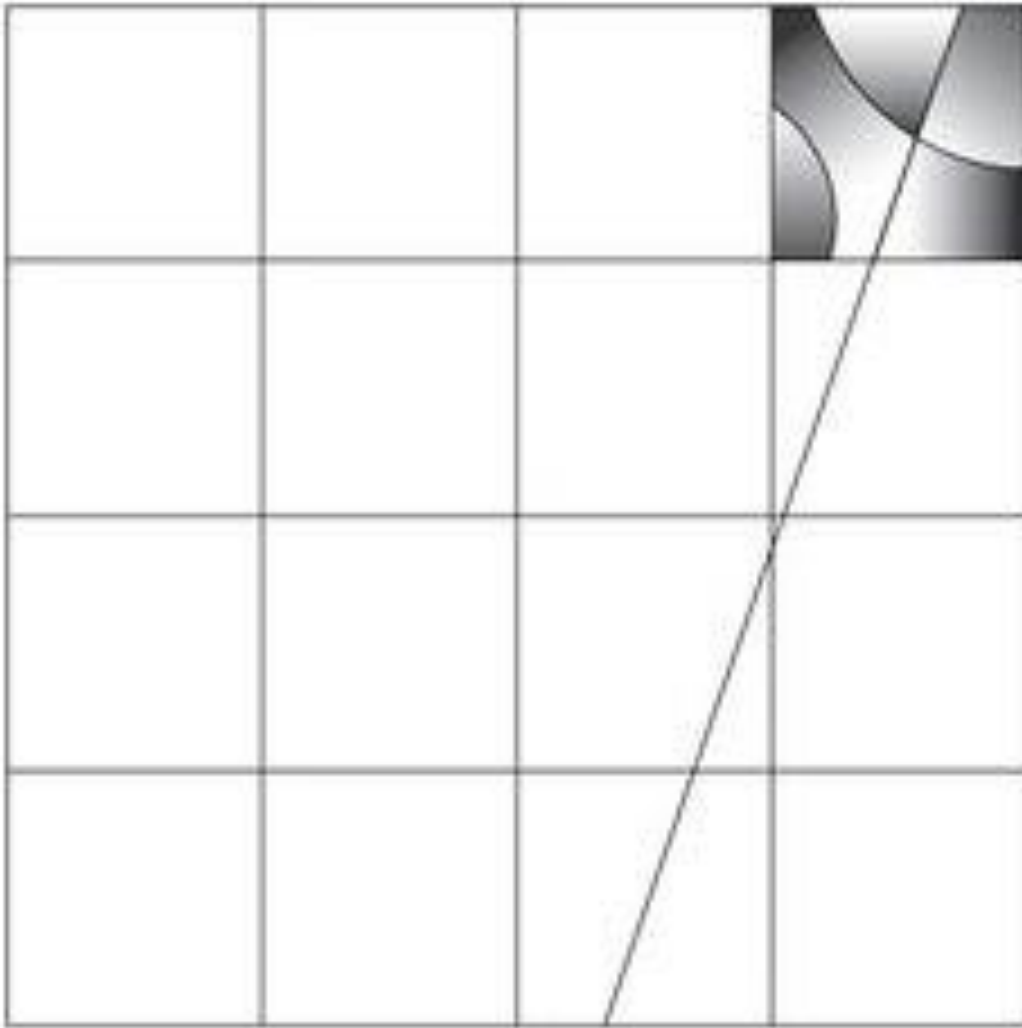

**Task:**

Copy the lines onto the template.

Number each box to help you work out what lines go where.  
Shade the areas with pencil. Use light & shade.

Pay attention to detail.

Use a rubber to add Highlights.

Effort:  
WWW:  
EBI:

## Key Words –

<b>Portrait</b>	<b>Self Portrait</b>	<b>Tone</b>	<b>Texture</b>	<b>Value Scale</b>	<b>Mona Lisa</b>	<b>Artist</b>
<b>Proportion</b>	<b>Structure</b>	<b>Develop</b>	<b>Shadow</b>	<b>Highlight</b>	<b>Blending</b>	<b>Mark Making</b>
<b>Base colour</b>	<b>Mid Tone</b>	<b>Circular motion</b>	<b>Hatching</b>	<b>Template</b>	<b>Angle</b>	<b>Water colour</b>
<b>Style</b>	<b>Compose</b>	<b>Illusion</b>	<b>Warm</b>	<b>Cold</b>	<b>Vibrant</b>	<b>Bold</b>
<b>Delicate</b>	<b>Elegant</b>	<b>Intense</b>	<b>Expressive</b>	<b>Layers</b>	<b>Fine Art</b>	<b>Light</b>
<b>Shade</b>	<b>Geometric</b>	<b>Natural</b>	<b>Photographic</b>	<b>Refined</b>	<b>Stylised</b>	<b>Surreal</b>
<b>Timeless</b>	<b>Vibrant</b>	<b>Vivid</b>	<b>Symmetrical</b>	<b>Line</b>	<b>Mood</b>	<b>Media</b>
<b>Still Life</b>	<b>Pattern</b>	<b>Culture</b>	<b>Observational</b>	<b>Graphite</b>	<b>Collage</b>	<b>Acrylic</b>
<b>Chalk</b>	<b>Pastel</b>	<b>Crayon</b>	<b>Application</b>	<b>Sculpture</b>	<b>Engrave</b>	<b>Design</b>
<b>Smooth</b>	<b>Skin tone</b>	<b>Abstract</b>	<b>Monochrome</b>	<b>Rich Tones</b>	<b>Continuous</b>	<b>Zigzag</b>
<b>Horizontal</b>	<b>Repetitive</b>	<b>Primary</b>	<b>Secondary</b>	<b>Neutral</b>	<b>Form</b>	<b>Curved</b>
<b>Balanced</b>	<b>Focal Point</b>	<b>Angular</b>	<b>Stippling</b>	<b>Creative</b>	<b>Contrast</b>	<b>Depth</b>
<b>Space</b>	<b>Brushes</b>	<b>Font</b>	<b>Negative Space</b>	<b>Colourful</b>	<b>Foreground</b>	<b>Background</b>

Use this space to practice your work

Use this space to practice your work

Use this space to practice your work

Use this space to practice your work